



# COMPOSITE ROOF SYSTEM WITH STANDING SEAM 360

## 1. PRODUCT NAME

Composite Roof System for roof applications.

## 2. MANUFACTURER

### AMERICAN BUILDINGS COMPANY

1150 State Docks Road  
Eufaula, Alabama 36027  
Phone: (334) 687-2032

## 3. PRODUCT DESCRIPTION

These standing seam panels float on a system of sliding clips that prevent damage from thermal expansion and contraction. Standing seam designs also eliminate 80% of the through fasteners found in other systems for greater weathertightness. Standing Seam 360 panels provide 24" width coverage with 2" high ribs – 3" including the seam. Minimum roof slope for the Standing Seam 360 roof panels is ¼ to 12.

**Basic Use:** A roof covering system for new or retrofit construction. A specially designed roof system combines American's Standing Seam 360 roof panel with a layer of rigid insulation board and a Multi-rib liner panel giving the interior a finished look with excellent insulating properties.

The Multi-rib liner has 15/16" ribs with major corrugations spaced on 6" centers. They offer 36" width coverage. Thermax rigid insulation is applied between the interior and exterior panels. A compressible blanket insulation (unfaced) 1" thickness before compression is located between the exterior panel and the rigid insulation (while optional, this insulation is highly recommended to minimize panel rumbling in high winds). An optional 3 mil (or equivalent) vinyl vapor barrier may be used between the liner panel and the rigid insulation.

**Materials:** Standing Seam 360 panels are available in 24 or 22 gage 50,000 psi in either G90 zinc-coated (galvanized) steel or aluminum-zinc alloy-coated (AZ50 or AZ55) steel. Pre-painted panels have American Buildings Company's SmartKote (Kynar 500®) or Silicone Modified Polyester Finish. Rigid insulation is Thermax® by Celotex Corporation, Types TF600, TF604, TF610 or Thermax Plus with a maximum thickness of 5-1/2" in a double layer or 4-1/2" in a single layer.

The Standing Seam 360 concealed (S3PC-\_) clip is a two part assembly. The tab portion is die formed 0.031 thick aluminum-zinc alloy-coated steel. The base shall be die formed 12 gage zinc-coated (galvanized) material 2-1/4" high and 6" long. The expansion capability is 2-1/2". For higher uplift values requirements, optional panel clips (S3PC-\_R) consists of panel clip (S3PC-\_) with an additional panel to clip fastening base which is 16 gage, zinc-coated (galvanized) material are available. Bearing plates for the Standing Seam 360 panel clips are 20 gage zinc-coated (galvanized) or aluminum-zinc alloy-coated steel. Standing Seam 360 sidelaps have factory applied mastic, SikaLastomer-511 or equal. Its composition is 85% solids by weight. Service temperature range is -60°F to + 220°F.

Endlaps, roof flashing laps, ridges and eave closures are sealed with tape mastic, Sika Sika-Tape TC-95 or equal. The material is

non-staining, non-corrosive, non-toxic and non-volatile. Composition is 100% solid ethylene propylene copolymer tape. Service temperature is -60°F to +212°F. Eaves, endlaps, ridge and eave closures are sealed with non-skinning butyl caulk, SikaLastomer-511 or equal. Its composition is 85% solids by weight. Service temperature range is -60°F to + 220°F. All gutter and downspout joints, and roof accessories are sealed with polyurethane caulk, Sika SikaFlex 219LM or equal. It meets or exceeds Federal Specification TT-S-00230C, Type II, Class A.

All fasteners for panel to secondary framing and panel to panel will be one of the following EPDM washer head screws.

**A.** Premium roof fasteners shall be No. 14 x 1" self-drilling carbon steel screws with a molded zinc alloy or capped stainless steel cupped hex washer head. Premium roof fasteners will be on all warranted roofs and all pre-finished roofs.

**B.** Standard roof fasteners shall be No. 14 x 1" self-drilling carbon steel screws with an integral hex washer head. Standard roof fasteners shall have a corrosive resistant coating over zinc plating. Standard roof fasteners shall be on unwarranted aluminum-zinc, alloy-coated roofs only. Standing Seam 360 panel clips are attached to the purlins with self-drilling carbon steel screws No. 12 hex head, cadmium or zinc plated. The screw length is determined by the thickness of the rigid insulation. Multi-rib panels are attached to the secondary framing members by self-drilling carbon steel screws, No. 12 x 1-1/4" hex head, cadmium or zinc plated. Panel sidelaps are stitched with self-drilling carbon steel screws, No. 14 x 7/8" cadmium or zinc plated.

## 4. TECHNICAL DATA

The Standing Seam 360 panel has received a Class 90 Wind Uplift rating by Underwriters Laboratories when tested in accordance with test procedure UL 580. The Standing Seam 360 roof panel has been Factory Mutual and Miami-Dade County approved. This panel has been tested in accordance with Wind Uplift ASTM E1592 and CEGS 07416, Air Infiltration, ASTM E1680 and Water Penetration, ASTM E1646. This panel has been approved for SREF (SSTD-97) Impact Testing. This panel has received a Class A fire rating when tested in accordance with test procedure ASTM E108.

## 5. INSTALLATION

Installation should be performed in accordance with American Buildings Company's manuals and building erection drawings, and should be by a qualified installer using proper tools and equipment. Systems are installed by American Buildings Company Authorized Builders.

...continued



# COMPOSITE ROOF SYSTEM WITH STANDING SEAM 360

## 6. AVAILABILITY

For availability, contact:

**AMERICAN BUILDINGS COMPANY**

## 7. WARRANTY

Thirty-five year material and twenty year weathertightness warranties are available.

## 8. MAINTENANCE

Only normal routine maintenance is required over the life of the panels.

## 9. TECHNICAL SERVICES

For information, contact:

## AMERICAN BUILDINGS COMPANY

## 10. PRODUCT NOTES

A certain amount of waviness called "oilcanning" may exist in this panel. Minor waviness of the panel is not sufficient cause for rejection, because oilcanning does not affect the structural integrity of the panel.

American Buildings Company reserves the right to revise all standard specifications and information. American Buildings Company regularly updates its published "Standard Specifications" on the American Buildings web site, [www.americanbuildings.com](http://www.americanbuildings.com), which supercede and replace any previously published standard specifications of American Buildings Company.

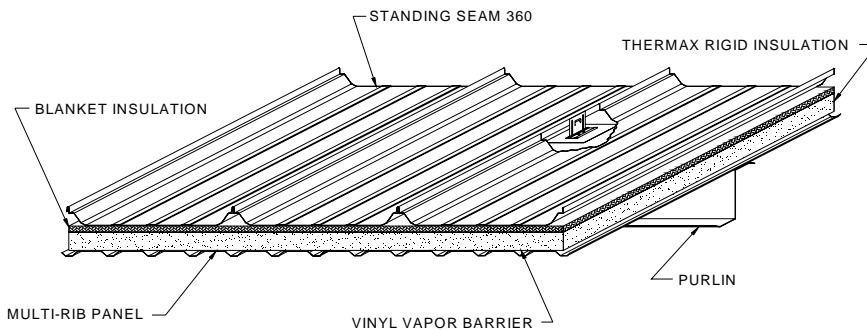

**System "R" Values**

Thermax	Winter	Summer
1"	9.8	10.5
1 1/2"	13.8	14.1
2"	17.8	17.7
2 1/2"	21.8	21.3
3"	25.8	24.9
4"	33.8	32.1

**Engineering Properties of American Buildings Company Standing Seam 360 Panel**

Designated Gage of Steel	Steel Yield KSI	Base Metal Thick. (In.)	Total Thick. (In.)	Panel Weight (lbs. / ft. <sup>2</sup> )	Top In Compression			Bottom In Compression			Fb KSI
					Ix (In. <sup>4</sup> / ft.)	Sx (In. <sup>3</sup> / ft.)	Ma K-IN.	Ix (In. <sup>4</sup> / ft.)	Sx (In. <sup>3</sup> / ft.)	Ma K-IN.	
24 Ga.	50	0.0225	0.0241	1.20	0.278	0.116	3.48	0.126	0.080	2.40	30
22 Ga.	50	0.0300	0.0316	1.58	0.372	0.158	4.74	0.177	0.111	3.33	30

Gage of Panel	No. of Spans	Load Type	Maximum Total Uniform Load in PSF							
			Span Lengths, Ft.							
			1.50	2.00	2.50	3.00	3.50	4.00	4.50	5.00
24 Ga.	1	POS	744	471	322	232	175	136	109	89
	2	POS	548	340	229	164	123	96	76	62
	3	POS	630	401	275	199	150	117	94	77
	4	POS	605	382	260	188	141	110	88	72
22 Ga.	1	POS	1085	673	453	325	243	189	151	123
	2	POS	800	488	326	232	173	134	107	87
	3	POS	932	582	394	283	212	165	132	107
	4	POS	891	552	372	266	200	155	123	101

- The panels were checked for bending, shear, combined bending and shear, and deflection. Deflection was limited to span/150
- Section Properties have been calculated in accordance with the 2001 *North American Specification for the Design of Cold-Formed Steel Structural Members*.
- Minimum yield strength of 24 and 22 gage steel is 50,000 psi.
- Steel panels are either aluminum-zinc alloy or G-90 coated. The base metal thickness was used in determining section properties.
- Positive load (POS) is applied inward toward the panel supports and is applied to the outer surface of the full panel cross-section.