



16" LOC SEAM / LOC SEAM 360 PANEL SPECIFICATIONS

1. PRODUCT NAME

American Loc Seam panel for roof applications.

2. MANUFACTURER

AMERICAN BUILDINGS COMPANY

1150 State Docks Road
Eufaula, Alabama 36027
Phone: (334) 687-2032

3. PRODUCT DESCRIPTION

These standing seam roof panels offer a flat profile with minor striations and optional pencil ribs for an attractive appearance on higher pitched roofs. Loc Seam panels are seamed electrically and Loc Seam 360 panels have full 360 degree rolled seams formed with an electrical seaming machine. Minimum roof slope for the Loc Seam/Loc Seam 360 roof panels is ¼ to 12.

Basic Use: A roof covering system for new or retrofit construction.

Materials: Loc Seam panels are available in 24 or 22 gage 50,000 psi in either G90 zinc-coated (galvanized) steel or aluminum-zinc alloy-coated (AZ50 or AZ55) steel. Pre-painted panels have American Buildings Company SmartKote (Kynar 500®) Finish. Panel clips for the Loc Seam panels are two part assemblies. The tab portions are a nominal 2-3/8" or 3-1/8" (for thermal blocks) in height and 3" in width, die formed 24 gage aluminum coated steel. The bases are die formed 18 gage zinc-coated (galvanized) steel. Expansion capability is 1-1/4".

Loc Seam panel sidelaps have factory applied mastic, SikaLastomer-511 or equal. Its composition is 85% solids by weight. Service temperature range is -60°F to + 220° F.

Endlaps, roof flashing laps, ridges, and eave closures are sealed with tape mastic, Sika Sika-Tape TC-95 or equal. The material is non-staining, non-corrosive, non-toxic and non-volatile. Composition is 100% solid ethylene propylene copolymer tape. Service temperature is -60°F to + 212° F.

Caulk: Eaves, endlaps, ridge and eave closures are sealed with non-skinning butyl caulk, SikaLastomer-511 or equal. Its composition is 85% solids by weight. Service temperature range is -60°F to + 220°F. All gutter and downspout joints, and roof accessories are sealed with polyurethane caulk, Sika SikaFlex 219LM or equal. It meets or exceeds Federal specification TT-S-00230C, Type II, Class A.

All fasteners for panel to secondary framing and panel to panel will be one of the following EPDM washer head screws.

A. Premium roof fasteners shall be No. 14 x 1" self-drilling carbon steel screws with a molded zinc alloy or capped stainless steel cupped hex washer head. Premium roof fasteners will be on all warranted roofs and all pre-finished roofs.

B. Standard roof fasteners shall be No. 14 x 1" self-drilling carbon steel screws with an integral hex washer head. Standard roof fasteners shall have a corrosive resistant coating over zinc plating. Standard roof fasteners shall be on unwarranted aluminum-zinc alloy-coated roofs only.

Loc Seam panel clips are attached to the purlins with self-drilling carbon steel screws No. 12 x 1-1/4" hex head, cadmium or zinc plated.

Maximum insulation thickness allowed with these panels is 4" without thermal blocks and 6" with thermal blocks and tall clips.

4. TECHNICAL DATA

The Loc Seam 360 panel has received a Class 90 Wind Uplift rating by Underwriters Laboratories when tested in accordance with test procedure UL 580. The Loc Seam 360 roof panel has been Factory Mutual and Miami-Dade County approved and also tested in accordance with Wind Uplift ASTM E1592 and CEGS 07416. This panel has been tested in accordance with Air Infiltration, ASTM E1680 and Water Penetration, ASTM E1646. This panel has been approved for SREF (SSTD-97) Impact Testing. This panel has received a Class A fire rating when tested in accordance with test procedure ASTM E108. The Loc Seam panel has received a Class 90 Wind Uplift rating by Underwriters Laboratories when tested in accordance with test procedure UL 580. The Loc Seam roof panel has been tested in accordance with CEGS 07416. This panel has also been tested in accordance with Air Infiltration, ASTM E1680, ASTM E283 and Water Penetration, ASTM E1646, ASTM E331. This panel has received a Class A fire rating when tested in accordance with test procedure ASTM E108.

5. INSTALLATION

Panels are joined at the sidelap with an interlocking seam. Panel sidelaps are seamed by a special electrical seaming machine. Sidelap sealer is factory applied. Roof systems are installed by American Buildings Company Authorized Builders. Installation may be incorporated with a light gage structural system.

6. AVAILABILITY

For availability, contact:

AMERICAN BUILDINGS COMPANY

7. WARRANTY

Thirty-five year material and twenty year weathertightness warranties are available.

8. MAINTENANCE

Only normal routine maintenance is required over the life of the panels.

9. TECHNICAL SERVICES

For information, contact:

AMERICAN BUILDINGS COMPANY

...continued



16" LOC SEAM / LOC SEAM 360 PANEL SPECIFICATIONS

10. PRODUCT NOTES

A certain amount of waviness called "oilcanning" may exist in this panel. Minor waviness of the panel is not sufficient cause for rejection, because oilcanning does not affect the structural integrity of the panel.

Loc Seam Panels in general are known for their tendency to rattle in high winds if insulation is not used. An insulation spacer strip (FS-1) should be used along the roof purlins whenever insulation is not required in the roof system.

American Buildings Company reserves the right to revise all standard specifications and information. American Buildings Company regularly updates its published "Standard Specifications" on the American Buildings web site, www.americanbuildings.com, which supercede and replace any previously published standard specifications of American Buildings Company.

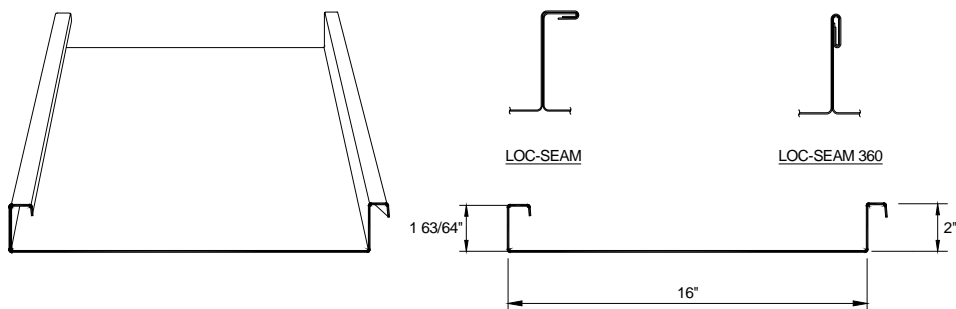

PANEL PROFILE

CROSS SECTION

Engineering Properties of American Buildings Company 16" LocSeam Panel											
Designated Gage of Steel	Steel Yield KSI	Base Metal Thick. (In.)	Total Thick. (In.)	Panel Weight (lbs. / ft. ²)	Top In Compression			Bottom In Compression			Fb KSI
					Ix (In. ⁴ / ft.)	Sx (In. ³ / ft.)	Ma K-IN.	Ix (In. ⁴ / ft.)	Sx (In. ³ / ft.)	Ma K-IN.	
24 Ga.	50	0.0225	0.0241	1.35	0.166	0.099	2.97	0.073	0.061	1.83	30
22 Ga.	50	0.0300	0.0316	1.77	0.225	0.140	4.20	0.110	0.094	2.82	30
Gage of Panel	No. of Spans	Load Type	Maximum Total Uniform Load in PSF								
			Span Lengths, Ft.								
			1.50	2.00	2.50	3.00	3.50	4.00	4.50	5.00	
24 Ga.	1	POS	683	423	285	204	153	118	94	77	
	2	POS	460	276	183	129	96	74	59	48	
	3	POS	542	332	222	159	118	92	73	60	
	4	POS	516	314	210	149	111	86	68	56	
22 Ga.	1	POS	1042	629	417	296	220	170	135	110	
	2	POS	733	435	286	201	149	115	91	74	
	3	POS	873	527	350	248	185	143	113	92	
	4	POS	828	497	329	233	173	134	106	86	
Engineering Properties of American Buildings Company 16" LocSeam 360 Panel											
Designated Gage of Steel	Steel Yield KSI	Base Metal Thick. (In.)	Total Thick. (In.)	Panel Weight (lbs. / ft. ²)	Top In Compression			Bottom In Compression			Fb KSI
					Ix (In. ⁴ / ft.)	Sx (In. ³ / ft.)	Ma K-IN.	Ix (In. ⁴ / ft.)	Sx (In. ³ / ft.)	Ma K-IN.	
24 Ga.	50	0.0225	0.0241	1.35	0.140	0.078	2.34	0.063	0.056	1.68	30
22 Ga.	50	0.0300	0.0316	1.77	0.195	0.114	3.42	0.095	0.085	2.55	30
Gage of Panel	No. of Spans	Load Type	Maximum Total Uniform Load in PSF								
			Span Lengths, Ft.								
			1.50	2.00	2.50	3.00	3.50	4.00	4.50	5.00	
24 Ga.	1	POS	613	363	238	168	124	96	76	62	
	2	POS	450	264	172	121	90	69	55	44	
	3	POS	541	322	212	150	111	86	68	55	
	4	POS	512	303	199	140	104	80	64	52	
22 Ga.	1	POS	929	542	353	248	183	141	111	90	
	2	POS	700	407	264	185	137	105	83	68	
	3	POS	849	499	326	229	170	131	104	84	
	4	POS	801	469	306	215	159	122	97	79	

1. The panels were checked for bending, shear, combined bending and shear and deflection. Deflection was limited to span/150
2. Section Properties have been calculated in accordance with the 2001 *North American Specification for the Design of Cold-Formed Steel Structural Members*.
3. Minimum yield strength of 24 and 22 gage steel is 50,000 psi.
4. Steel panels are either aluminum-zinc alloy or G-90 coated. The base metal thickness was used in determining section properties.
5. Positive load (POS) is applied inward toward the panel supports and is applied to the outer surface of the full panel cross-section.